

Enroll Online



1. From the WLAC home page at www.wlac.edu, click REGISTER ONLINE in the upper right corner. Then, click the "Student Information Link" button. The Student Information System (SIS) page will be displayed



2. Click on Student Information System link.
- 3 The SIS menu will be displayed. Click on Student Information System.

4. The SIS Sign-on page will be displayed.

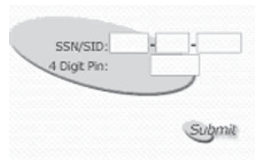

Sign-on to SIS:

- Enter your Student ID or Social Security number in the SSN/SID field
- Enter your 4-digit PIN (default PIN: month and day of birth)
- Click on Submit button.



5. The main menu will be displayed. Click on Registration option.

6. The Registration page will be displayed.
 - Select the following:
 - College
 - Semester and Year
 - Action (i.e., Add or Drop)
 - Type in the Section Number.
 - Click on Submit button

A message will be displayed indicating results of Add or Drop operation.

Be sure to write down your confirmation number.

Enroll by Phone



To use the Student Telephone Enrollment Program (STEP), call one of the following automated telephone numbers.

(310) 605-0505 (323) 226-1999
(213) 689-8888 (818) 988-2222

Please complete the form on the next page before calling STEP

STEP 1: Dial one of the numbers above and listen to the detailed instructions.

Press * at any time to correct a mistake, or # to return to the main menu.

STEP 2: Press 9 for West Los Angeles College.

STEP 3: Press 1 for Spring, 2 for Summer, 3 for Fall, 0 for Winter.

STEP 4: Enter your Social Security, or Student ID Number (without dashes).

STEP 5: Enter your PIN (month and day of birth).

STEP 6: Choose one of the options from the menu to check appointment date/time, add/drop classes, check your grades and schedule, review your fees, etc.

STEP 7: Register for classes, using the CLASS SCHEDULE WORKSHEET.

STEP 8: Respond to STEP's request for information including a request for your Major Code

(see the Major Code List on page 14)

STEP 9: Complete the FEES WORKSHEET and select your method of payment.

REGISTRATION MENU OPTIONS

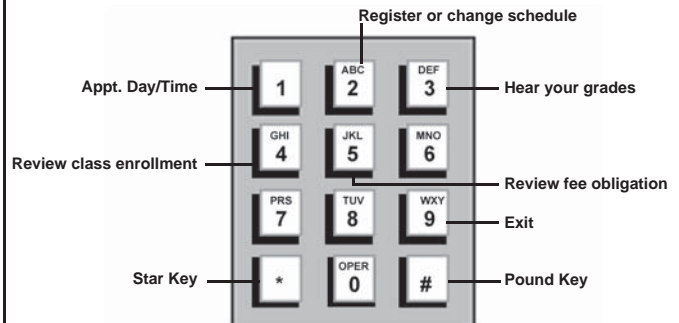

STEP Worksheet

Use this worksheet to plan your class schedule. Fill it in before you call STEP and keep it handy while registering.

When you select your classes from the Schedule of Classes, enter the

- 4-digit class section number Example 5061
 - Class name and number Example "English 21"
 - Number of units the class gives Example 3
- You will get your registration status from STEP Example A-Active, S-Standby List

Section Number	Course Name	Time	Day(s)	Units	Alternate

FEES WORKSHEET

The fees listed were accurate at the time this schedule went to print but are subject to change by the California Legislature.

A: Enrollment fees		\$ 26.00	x _____	units =	\$ _____
B: Non-Resident Tuition for Out-of-State residents		\$188.00	x _____	units =	\$ _____
C: Non-Resident Tuition for International Students and/or F-1 VIS (Non-Resident International Students must also pay the enrollment fee of \$20 per unit + \$25 application + \$420 insurance)		\$198.00	x _____	units =	\$ _____
D: Health Center fee (mandatory) (\$8 Sum, \$11 Spr & Fall)		\$ _____			\$ _____
E: ASO membership (\$3 Sum, \$7 Spr & Fall)		\$ _____			\$ _____
F: Parking Permit (\$TBD Sum, \$20 Spr & Fall)		\$ _____			\$ _____
G: Student Political Representation Fee (mandatory)	\$ 1.00	\$ 1.00			\$ _____
TOTAL FEES DUE:					\$ _____

PAYMENT OPTIONS

- In Person:** Pay by cash, electronic check, debit or credit card at the Business Office
- By Mail:** Pay by electronic check or money order.
WLAC Business Office 9000 Overland Ave./ Culver City, CA 90230
- On-Line:** Pay by Visa, Mastercard, American Express, Discover
- Via Step:** Pay by Visa, Mastercard, American Express, Discover